



# HEIDENHAIN



**Functional  
Safety**

Product Information

## **ECI 1119 EQI 1131**

Absolute Rotary  
Encoders without  
Integral Bearing

Suitable for safety-related  
applications up to SIL 3  
when coupled with  
additional measures

# ECI 1119, EQI 1131

Rotary encoders for absolute position values with safe singleturn information

- Rugged inductive scanning principle
- Mounting-compatible with photoelectric rotary encoders with 75A stator coupling
- 70C mounting flange
- Ø 6 mm blind hollow shaft for axial clamping with positive-locking element (1KA) or without (82A)
- Required mating dimensions with M3×25 central screw and version for customer cost optimization upon request

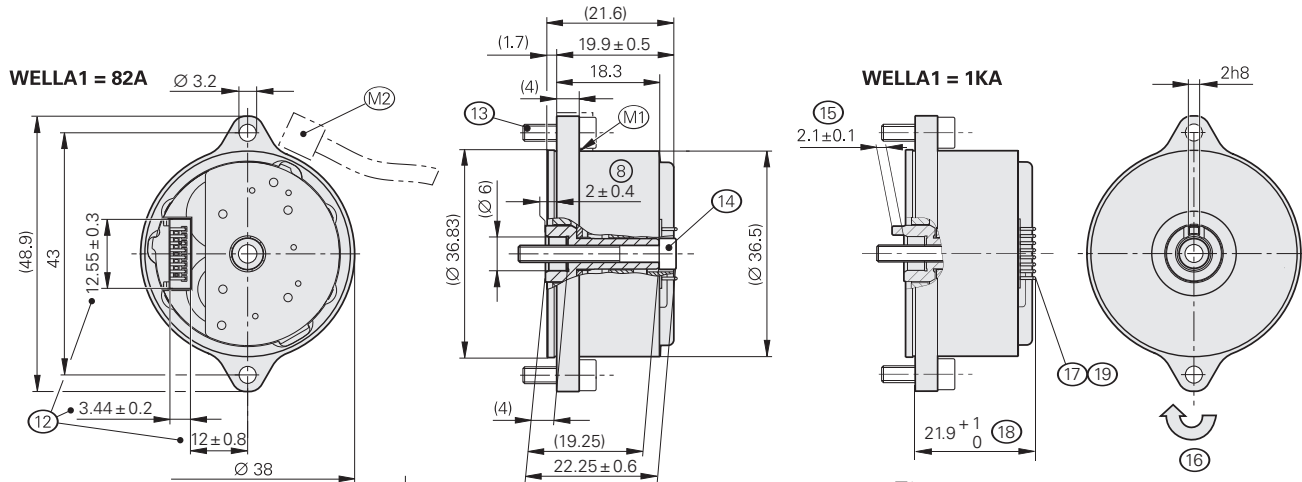

## Required mating dimensions

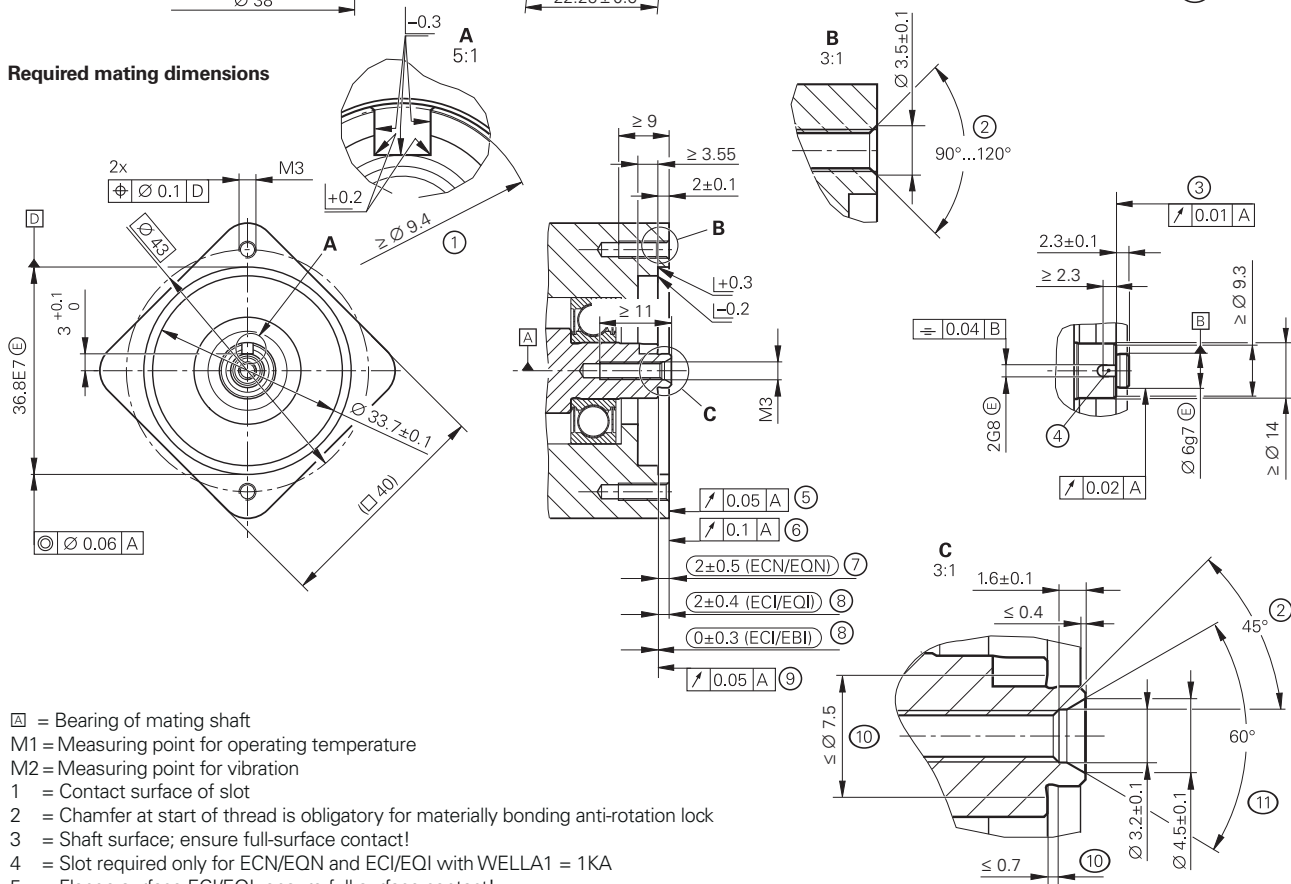

- ☐ = Bearing of mating shaft
- M1 = Measuring point for operating temperature
- M2 = Measuring point for vibration
- 1 = Contact surface of slot
- 2 = Chamfer at start of thread is obligatory for materially bonding anti-rotation lock
- 3 = Shaft surface; ensure full-surface contact!
- 4 = Slot required only for ECN/EQN and ECI/EQI with WELLA1 = 1KA
- 5 = Flange surface ECI/EQI; ensure full-surface contact!
- 6 = Coupling surface ECN/EQN
- 7 = Maximum permissible deviation between shaft surface and coupling surface. Compensation for mounting tolerances and thermal expansion, of which ±0.15 mm of dynamic axial motion is permitted (ECN/EQN)
- 8 = Maximum permissible deviation between shaft surface and coupling surface. Compensation for mounting tolerances and thermal expansion; dynamic motion permitted over entire range (ECI/EBI/EQI)
- 9 = Flange surface ECI/EBI; ensure full-surface contact!
- 10 = Undercut
- 11 = Possible centering hole
- 12 = Distance to cover; take the opening for pin header, socket connector, and wires into account
- 13 = Screw: ISO 4762 – M3x10 – 8.8 – MKL, tightening torque: 1±0.1 Nm
- 14 = Screw ISO: 4762 – M3x25 – 8.8 – MKL, tightening torque: 1±0.1 Nm
- 15 = Positive-locking element; ensure correct engagement in slot (e.g., by measuring the device overhang)
- 16 = Direction of shaft rotation for ascending position values
- 17 = Pin header for 15 pins
- 18 = Dimension for JH standard cable
- 19 = Take installation space for cable into account

mm  
  
 Tolerancing ISO 8015  
 ISO 2768 - m H  
 ≤ 6 mm: ±0.2 mm

Specifications	ECI 1119 – Singletum	EQI 1131 – Multitum
Valid for	1KA shaft: ID 1164809-01/-51 <sup>1)</sup> 82A shaft: ID 1164809-02/-52 <sup>1)</sup>	1KA shaft: ID 1164811-01/-51 <sup>1)</sup> 82A shaft: ID 1164811-02/-52 <sup>1)</sup>
<b>Functional safety</b> for applications up to	As single-encoder system for monitoring and closed-loop functions: <ul style="list-style-type: none"> <li>• SIL 2 as per EN 61508 (further basis for testing: EN 61800-5-2)</li> <li>• Category 3, PL d as per EN ISO 13849-1:2015</li> </ul> With additional measures as per document 1000344 for safety-related applications up to SIL 3 or Category 4, PL e Safe in singletum range	
PFH	SIL 2: $\leq 15 \cdot 10^{-9}$ (probability of dangerous failure per hour) SIL 3: $\leq 2 \cdot 10^{-9}$	
Safe position <sup>2)</sup>	Encoder: $\pm 0.88^\circ$ (safety-relevant measuring step: SM = $0.35^\circ$ ) Mechanical coupling for 82A shaft: $\pm 0^\circ$ ; for 1KA shaft: $\pm 2^\circ$ (fault exclusion for loosening of shaft coupling and stator coupling, designed for accelerations of $\leq 400 \text{ m/s}^2$ on the stator and $\leq 600 \text{ m/s}^2$ on the rotor)	
<b>Interface</b>	EnDat 2.2	
Ordering designation	EnDat22	
Position values/per rev.	524 288 (19 bits)	
Revolutions	-	4096 (12 bits)
Calculation time $t_{\text{cal}}$ Clock frequency	$\leq 5 \mu\text{s}$ $\leq 16 \text{ MHz}$	
<b>System accuracy</b>	$\pm 120''$	
<b>Electrical connection</b>	15-pin PCB connector (with connection for external temperature sensor <sup>3)</sup> )	
Cable length	$\leq 100 \text{ m}$ (see EnDat description in the <i>Interfaces of HEIDENHAIN Encoders</i> brochure)	
Supply voltage	DC 3.6 V to 14 V	
Power consumption <sup>4)</sup> (max.)	At 3.6 V: $\leq 650 \text{ mW}$ ; at 14 V: $\leq 700 \text{ mW}$	At 3.6 V: $\leq 750 \text{ mW}$ ; at 14 V: $\leq 850 \text{ mW}$
Current consumption (typical)	At 5 V: 95 mA (without load)	At 5 V: 115 mA (without load)
<b>Shaft*</b>	Blind hollow shaft for axial clamping, $\varnothing 6 \text{ mm}$ , with positive-locking element (1KA) or without (82A)	
Speed	$\leq 15000 \text{ rpm}$	$\leq 12000 \text{ rpm}$
Moment of inertia of rotor	$0.2 \cdot 10^{-6} \text{ kgm}^2$	
Angular acceleration of rotor	$\leq 1 \cdot 10^5 \text{ rad/s}^2$	
Axial motion of measured shaft	$\leq \pm 0.4 \text{ mm}$	
<b>Vibration</b> 55 Hz to 2000 Hz <sup>5)</sup> <b>Shock</b> 6 ms	Stator: $\leq 400 \text{ m/s}^2$ ; rotor: $\leq 600 \text{ m/s}^2$ (EN 60068-2-6) $\leq 2000 \text{ m/s}^2$ (EN 60068-2-27)	
<b>Operating temperature</b>	$-40 \text{ }^\circ\text{C}$ to $110 \text{ }^\circ\text{C}$	
<b>Trigger threshold</b> of error message for excessive temperature	$125 \text{ }^\circ\text{C}$ (measuring accuracy of internal temperature sensor: $\pm 1 \text{ K}$ )	
<b>Relative humidity</b>	$\leq 93 \%$ ( $40 \text{ }^\circ\text{C}/21 \text{ d}$ as per EN 60068-2-78); without condensation	
<b>Protection</b> EN 60529	IP00 (see <i>Insulation</i> under <i>General mechanical information</i> in the <i>Encoders for Servo Drives</i> brochure; ensure CE conformity of the overall system through installation measures!)	
<b>Mass</b>	$\approx 0.04 \text{ kg}$	

\* Please select when ordering

- 1) Rotary encoders in collective package
- 2) Further tolerances may apply in the subsequent electronics after position value comparison (contact mfr. of the subsequent electronics)
- 3) See *Temperature measurement in motors* in the *Encoders for Servo Drives* brochure
- 4) See *General electrical information* in the *Interfaces of HEIDENHAIN Encoders* brochure
- 5) 10 Hz to 55 Hz constant over 4.9 mm peak to peak

# Mounting

The blind hollow shaft of the rotary encoder is slid onto the measured shaft and fastened with a central screw. For the 1KA rotary encoder shaft, it is particularly important to ensure that the positive-locking element securely engages the corresponding slot in the measured shaft. The stator is connected with two mounting screws via a centering diameter. In each case, use screws with materially bonding anti-rotation lock (see *Mounting accessories*).

Requirements on the motor side for safe mechanical coupling:

	Mating stator	Mating shaft
Material type	Hardenable wrought aluminum alloy	Unalloyed hardened steel
Tensile strength $R_m$	$\geq 220 \text{ N/mm}^2$	$\geq 600 \text{ N/mm}^2$
Yield strength $R_{p0.2}$ or yield point $R_e$	Not applicable	$\geq 400 \text{ N/mm}^2$
Shear strength $\tau_a$	$\geq 130 \text{ N/mm}^2$	$\geq 390 \text{ N/mm}^2$
Interface pressure $P_G$	$\geq 250 \text{ N/mm}^2$	$\geq 660 \text{ N/mm}^2$
Modulus of elasticity $E$ (at 20 °C)	$\geq 70 \text{ kN/mm}^2$ to $75 \text{ kN/mm}^2$	$\geq 200 \text{ kN/mm}^2$ to $215 \text{ kN/mm}^2$
Coefficient of thermal expansion $\alpha_{\text{therm}}$ (at 20 °C)	$\leq 25 \cdot 10^{-6} \text{ K}^{-1}$	$10 \cdot 10^{-6} \text{ K}^{-1}$ to $17 \cdot 10^{-6} \text{ K}^{-1}$
Surface roughness $R_z$	$\leq 16 \mu\text{m}$	
Friction values	Mounting surfaces must be clean and free of grease. Use screws and washers in the condition as delivered.	
Tightening process	Use a signaling torque tool as per DIN EN ISO 6789; accuracy $\pm 6 \%$	
Mounting temperature	15 °C to 35 °C	

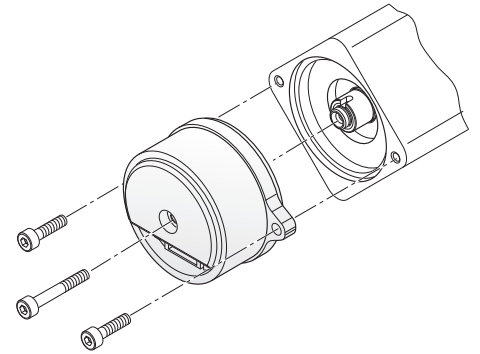

## Mounting Accessories

### Screws

Screws are not included in delivery. They can be ordered separately.

ECI 1119; EQI 1131	Screws <sup>1)</sup>		Lot size
<b>Central screw</b> for fastening the shaft	ISO 4762-M3×25-8.8-MKL	ID 202264-86	10 or 100
<b>Mounting screw</b> for flange	ISO 4762-M3×10-8.8-MKL	ID 202264-87	20 or 200

1) With coating for material bonding anti-rotation lock

Please note the information on screws from HEIDENHAIN in the *Encoders for Servo Drives* brochure, under *Rotary encoders with functional safety* in the *General mechanical information* chapter.

### Mounting aid

To avoid damage to the cable, use the mounting aid to connect and disconnect the cable assembly. The pulling force must be applied only to the connector of the cable assembly, and not to the wires.

ID 1075573-01

### Mounting aid

This tool is for turning the encoder shaft from the rear, thereby making it easy to find the positive-locking connection between the encoder shaft and the measured shaft.





ID 821017-03



**For further mounting information and mounting aids, refer to the mounting instructions and the *Encoders for Servo Drives* brochure. The installation can be inspected with the PWM 21 and the ATS software (see document 1082415).**

# Electrical connection – cables



## Cables

<b>Output cables inside the motor housing</b> with wires for temperature sensor: TPE 8 × 0.16 mm <sup>2</sup> <sup>1)</sup>		
<b>Output cable</b> with 15-pin PCB connector and 8-pin straight M12 flange socket (male), with TPE wires for temperature sensor		ID 1119952-xx <sup>3)</sup>
<b>Output cable</b> with 15-pin PCB connector and 8-pin straight M12 flange socket (male)		ID 804201-xx <sup>3)</sup>
<b>Output cable</b> with 15-pin PCB connector and free cable end (stripped), with TPE wires for temperature sensor		ID 1119958-xx <sup>3)</sup>
<b>Output cable</b> with 15-pin PCB connector and free cable end (stripped)		ID 640055-xx
<b>HMC 6 output cable:</b> Ø 3.7 mm EPG 1 × (4 × 0.06 mm <sup>2</sup> ) + 4 × 0.06 mm <sup>2</sup>		
<b>Output cable</b> with 15-pin PCB connector and contact insert for 6-pin HMC 6 hybrid connecting element (male), with two wires for temperature sensor		ID 1072652-xx

- 1) TPE single wires with heat-shrink tubing (without shield)
- 2) With cable clamp for shield connection
- 3) TPE single wires with braided sleeve (without shield)

Upon request, output cables inside the motor housing are available without wires for temperature sensor

**Note for safety-related applications:** Document the bit error rate as per Specification 533095!

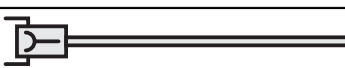
<b>PUR connecting and adapter cables</b> Ø 6 mm; 2 × (2 × 0.09 mm <sup>2</sup> ) + 2 × (2 × 0.16 mm <sup>2</sup> ); A <sub>P</sub> = 2 × 0.16 mm <sup>2</sup>		
<b>Connecting cable</b> with 8-pin M12 connector (female) and 8-pin M12 coupling (male)		ID 1036372-xx
<b>Adapter cable</b> with 8-pin M12 connector (female) and 15-pin D-sub connector (female)		ID 1036521-xx
<b>Adapter cable</b> with 8-pin M12 connector (female) and 15-pin D-sub connector (male)		ID 1036526-xx
<b>Connecting cable</b> with 8-pin M12 connector (female) and free cable end (unstripped)		ID 1129581-xx <sup>1)</sup>

A<sub>P</sub>: Cross section of power supply lines

- 1) Connecting element must be suitable for the maximum clock frequency used

**Note for safety-related applications:** Document the bit error rate as per Specification 533095!

# Electrical connection – pin layout

## Pin layout

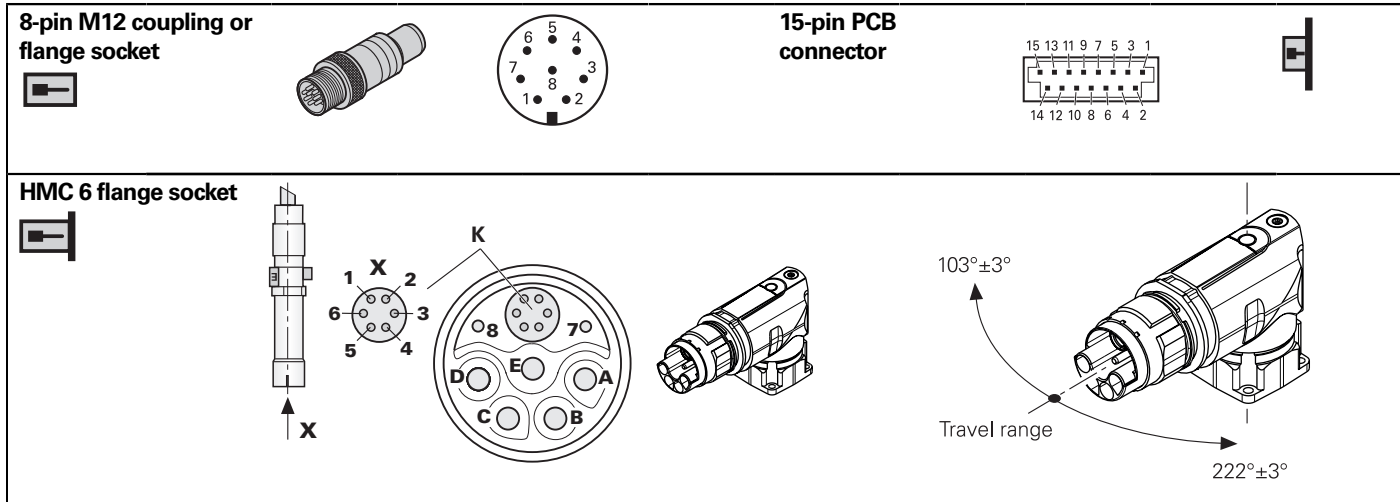

Encoder										
	Power supply				Serial data transfer				Other signals <sup>1)</sup>	
M12	8	2	5	1	3	4	7	6	/	/
HMC 6	1	/	2	/	3	4	5	6	/	/
	13	11	14	12	7	8	9	10	5	6
	<b>U<sub>p</sub></b>	Sensor <b>U<sub>p</sub></b>	<b>0 V</b>	Sensor <b>0 V</b>	<b>DATA</b>	<b>DATA</b>	<b>CLOCK</b>	<b>CLOCK</b>	<b>T<sup>+</sup>2)</b>	<b>T<sup>-</sup>2)</b>
	Brown/ Green	Blue	White/ Green	White	Gray	Pink	Violet	Yellow	Brown	Green

1) Only for adapter cables within the motor

2) Connections for external temperature sensor; evaluation optimized for KTY 84-130 (see *Temperature measurement in motors* in the *Encoders for Servo Drives* brochure)

Motor							
	Brake		Power				
	7	8	A	B	C	D	E
	<b>BRAKE-</b>	<b>BRAKE+</b>	<b>U</b>	<b>V</b>	<b>W</b>	/	<b>PE</b>
	White	White/Black	Blue	Brown	Black	/	Yellow/Green

External shield of the encoder output cable on communication element housing **K**.  
Unused pins or wires must not be assigned!

## HEIDENHAIN

DR. JOHANNES HEIDENHAIN GmbH

Dr.-Johannes-Heidenhain-Straße 5

83301 Traunreut, Germany

☎ +49 8669 31-0

FAX +49 8669 5061

E-mail: info@heidenhain.de

www.heidenhain.de

This Product Information document supersedes all previous editions, which thereby become invalid. The basis for ordering from HEIDENHAIN is always the Product Information document edition valid when the order is made.

**Further information:** Adhere to the information in the following documents to ensure the correct and intended operation of the encoder:

- *Encoders for Servo Drives* brochure: 208922-xx
- *Interfaces of HEIDENHAIN Encoders* brochure: 1078628-xx
- Mounting instructions for *ECI 1119, EQI 1131*: 1247146-xx
- *Safety-Related Position Measuring Systems* Technical Information document 596632
- For implementation in a safe control or inverter, refer to Specification 533095 and the *Supplementary Catalog of Measures (SIL 3, PL e)*: 1000344